

**JK GLOBAL SERVICE**

*Ergoline*

SUNANGEL

*soltron*

SUN DASH

**ERGOLINE  
SUNDASH / FLAIR / PASSION SERIES**

**SOLTRON  
XXS / XS SERIES**

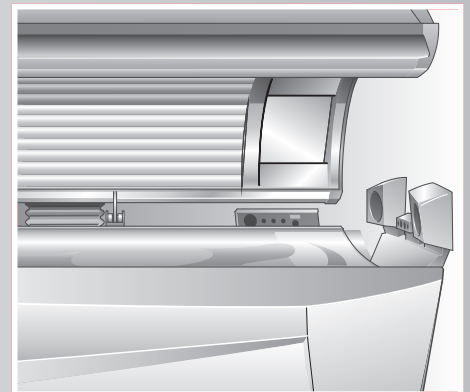
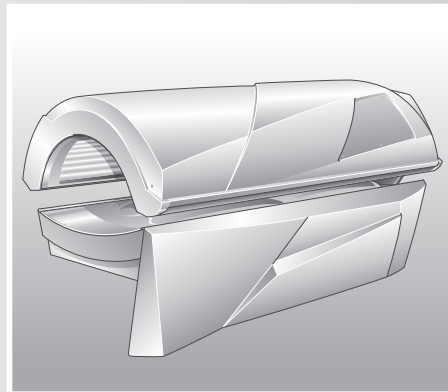
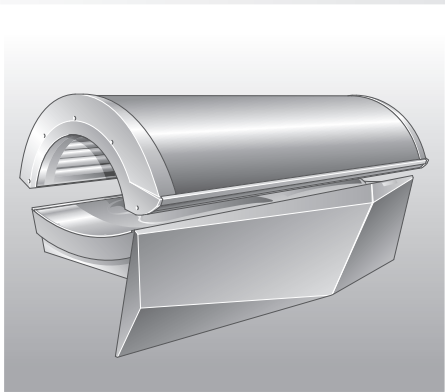

**OPERATING INSTRUCTIONS**

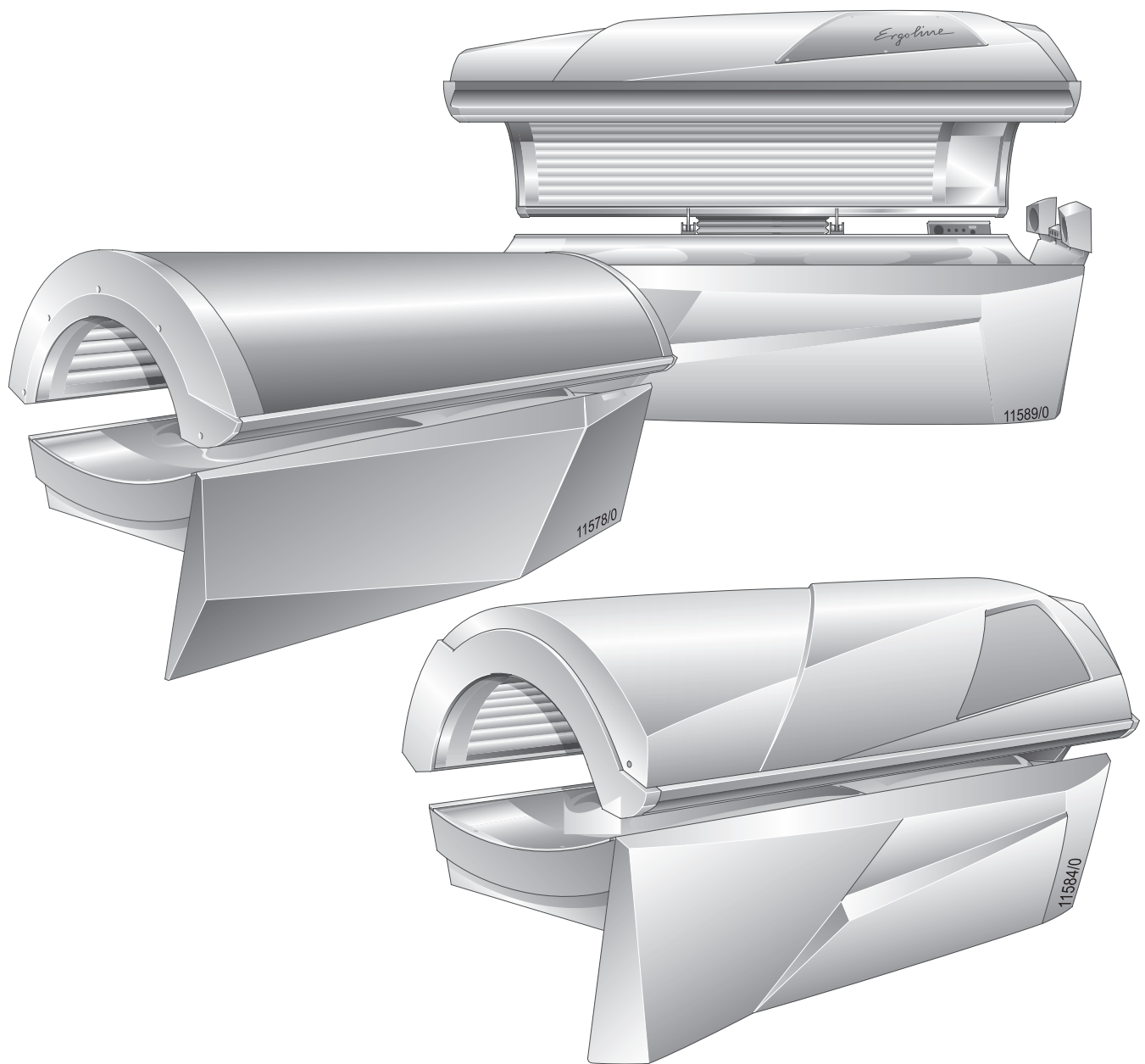

## Operating instructions (Part I)

**Ergoline SUNDASH / FLAIR / PASSION SERIES**  
**SOLTRON XXS / XS SERIES**

1006322-00 / us / 09.2009

**JK PRODUCTS**

*Ergoline*

SUNANGEL

*soltron*

SUNDASH

## Contact Information

**Technical Service: JK Global Service**  
A Div of JK Products & Services, Inc.  
#1 Walter Kratz Drive  
Jonesboro, AR 72401  
☎ 800-445-0624  
📠 870-935-9046  
e-mail: support@jkamerica.com  
<http://support.jkamerica.com>

See also Operating Instructions Part II (15 min or 20 min):

- Ergoline SUNDASH series
- Ergoline FLAIR series
- Ergoline PASSION series
- Soltron XXS-30 series
- Soltron XS-35 series
- Soltron XS-40 series



**WARNING!**

**WARNING!**  
**Read these operating instructions.**

**Failure to observe these instructions:**

- may result in serious injury and death,
  - can result in damage to the device and to the environment.
- “ For the safety of yourself and others, read and observe all instructions contained herein before operating the tanning system.
- “ Please make the instructions and additional information available to anyone who operates or services the tanning system.

---

### Copyright

The copyright remains with JK-Holding GmbH.

The contents may not be duplicated (in whole or part), distributed or utilized for competition purposes without authorization or disclosed to other parties.

The right to make technical changes in regard to the figures and information contained in this instruction manual is reserved!

## Table of contents

<b>1</b>	<b>General</b> .....	<b>5</b>
1.1	Definitions.....	5
1.2	Identify your tanning device.....	5
<b>2</b>	<b>Information for the studio operator</b> .....	<b>6</b>
2.1	Intended use.....	6
2.2	Foreseeable misuse .....	6
2.3	Obligations of the studio operator.....	6
2.4	Staff training .....	7
2.5	Guidelines .....	7
2.6	Installation location.....	7
	2.6.1 Ventilation .....	7
	2.6.2 Limits of installation location.....	8
2.7	Export.....	8
2.8	MP3 music (optional).....	8
2.9	Product information on acrylic glass panels .....	8
2.10	Disposal.....	9
	2.10.1 Environmental regulations – disposal of lamps .....	9
	2.10.2 Disposal of recyclable materials.....	9
2.11	Instruction signs on the device .....	9
2.12	Technical modifications .....	9
<b>3</b>	<b>Operation</b> .....	<b>10</b>
3.1	Mandatory reading .....	10
3.2	Use the sunbed – but use it properly!.....	10
3.3	Operation overview: SUNDASH / XXS.....	11
	3.3.1 Functions.....	11
3.4	Operation overview: FLAIR / PASSION / XS.....	12
	3.4.1 Navigation .....	12
	3.4.2 Functions.....	12
3.5	Start.....	13
	3.5.1 Preparation time.....	13
	3.5.2 Interrupt or end tanning session.....	13
3.6	MP3 player connection.....	14
<b>4</b>	<b>Cleaning and maintenance</b> .....	<b>15</b>
4.1	Safety instructions for cleaning and maintenance .....	15
4.2	Malfunctions .....	17
4.3	Cleaning .....	17
	4.3.1 Disinfection.....	17
	4.3.2 Cleaning of surfaces .....	18
	4.3.3 Filter panels and lamps .....	18
4.4	Cleaning plan – see Operating Instructions Part II .....	19

4.5	Maintenance .....	19
4.5.1	Acrylic base .....	19
4.6	Maintenance plan – see Operating Instructions Part II .....	19
4.7	Disassembly for cleaning and maintenance work .....	20
4.7.1	Removing the base .....	21
4.7.2	Removing the canopy panel .....	22
4.7.3	Removing the front panel .....	23
4.8	Instructions for changing the lamps .....	24
4.8.1	UV Low pressure lamps .....	24
4.8.2	Starter .....	25
4.8.3	High pressure lamps and filter panels .....	25
4.9	Cleaning or replacing UV lamps in the sunbed base .....	27
4.10	Cleaning or replacing UV lamps and filter panels in the canopy .....	28
4.11	Cleaning or replacing interior lighting .....	29
4.12	PASSION series: Cleaning or replacing the canopy accent lighting .....	29
4.13	Cleaning the base filter .....	30
<b>5</b>	<b>JK-Products, Inc. – Limited Warranty .....</b>	<b>31</b>
5.1	Limited Acrylic Warranty .....	32
5.2	Warranty Claims .....	32
5.2.1	Policy & Procedures .....	32
5.2.2	Labor Warranty Claim/Credit Procedures .....	33
5.3	Limited Lifetime Warranty .....	33
<b>6</b>	<b>Appendix .....</b>	<b>35</b>
6.1	Signs and stickers on the device .....	35
<b>7</b>	<b>Index .....</b>	<b>37</b>

---

**1****General**

---

**1.1 Definitions**

---

**(Studio) operator**

People who provide tanning devices to users on a commercial basis. The operator is responsible for the orderly operation of the device as well as the compliance with the maintenance intervals.

**User**

A person who uses the tanning device at a commercial location.

**Staff**

People who are responsible for the operation, cleaning as well as general maintenance work and who instruct the users in the operation of the devices.

**Electrician**

A person with suitable professional training, knowledge and experience which enables them to identify and avoid the dangers which can arise from working with electricity.

**Authorized and trained qualified staff**

Qualified staff from an external company who have been trained and authorized by the manufacturer for assembly and maintenance work with specific tanning devices.

---

**1.2 Identify your tanning device**

---

For contact with Customer Services, please write down the device number of your tanning device, see page 35.

## 2

## Information for the studio operator

### 2.1 Intended use

---

The tanning device is intended exclusively for cosmetic tanning of the human skin.

- This device is used for tanning one adult person at a time.
- The user must wear suitable eye protection to block UV radiation during tanning.

Any other use shall be considered improper. The manufacturer cannot be held liable for damage or injuries resulting from misuse. The operator bears the sole risk for this.

The proper use also includes compliance with the manufacturer's instructions, operating and maintenance conditions. This device may only be operated, maintained and repaired by persons familiar with these tasks and who are aware of the dangers involved.

### 2.2 Foreseeable misuse

---

The following uses of the device are explicitly prohibited:

- Multiple people may not use the device at the same time.
- People with body weight of more than 300 lb may not use the device.
- Exceeding the specified tanning times may result in burns and long-term skin damage.
- When the device is in use no other people may remain in the room. This includes both children and adults.

### 2.3 Obligations of the studio operator

---

- As the operator you are responsible for informing users on possible risks of tanning.
- All danger and safety labels attached to the device must be observed! Do not remove them!
- No safety equipment (e.g. panel switch) may be removed, deactivated, or otherwise bypassed as it can impair the safe operation of the device!
- The device may only be used when in completely operational condition!
- It is the operator's responsibility to ensure the tanning system is handled properly.

## 2.4 Staff training

As the operator you are obligated to train your personnel and instruct them in the established legal and accident prevention regulations. Ensure that your staff have understood and observe these instructions. This includes:

- information regarding intended use and foreseeable misuse
  - safety instructions in the "Operation" chapter
  - operating instructions
  - cleaning and maintenance instructions
- “ Please make the instructions and additional information from the manufacturer available to the staff at their workplace.
- “ Regularly check your staff's safety consciousness and awareness of the risks, taking into account your operating instructions.
- “ Please ensure that the cleaning intervals are complied with, in particular cleaning after every use.
- “ Please ensure that your staff provide your customers with appropriate advice, in particular regarding tanning times, possible risks and the operation of the device.

## 2.5 Guidelines

This product is in conformity with the performance standards for sunlamp products under 21 CFR 1040.20, FDA and listed with ETL and CAN/CSA 22.2 2 No. 224.

## 2.6 Installation location

### 2.6.1 Ventilation



#### CAUTION – DANGER OF FAILURE!

**Danger of overheating by obstruction of the air routing.**

Non-observance of the ventilation information in the Ergoline Planning Manual can lead to serious system malfunctions.

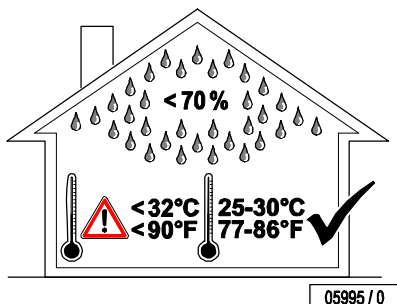

Data for air supply and extraction planning can be found in the Ergoline Planning manual. You can also ask for this data from your sales person or customer service (see Page 2).



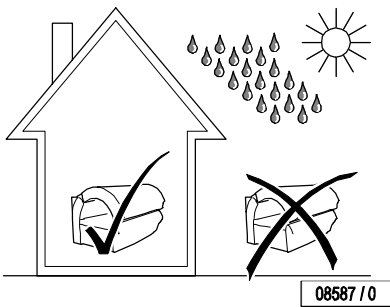

## 2.6.2 Limits of installation location

The tanning device must not be operated outside of buildings.

For altitudes greater than 6500 feet above sea level a conversion must be carried out to ensure trouble-free operation. Please contact Customer Service (see Page 2) before carrying out the conversion and starting up the unit for the first time.

## 2.7 Export

---

This device is exclusively intended for use in the USA and Canada and may not be exported to other countries and operated there! The manufacturer assumes no liability whatsoever in the event of non-compliance. High liability risks may occur for the exporter and/or the operator in the event of noncompliance.

## 2.8 MP3 music (optional)

---

The personal use of an MP3 player during tanning is not a public broadcast in copyright terms, so that there is no obligation for registration or payment by the studio owner to the corresponding copyright owning company in respect of copyright exists on the part of the studio operator.

The same regulations apply for the official use of MP3 music files as for other music sources: As studio owner you are only allowed to use original audio obtained from legal sources. Proof of the legitimacy of any MP3 audio used should be available for viewing upon demand of any regulatory body. Please refer to <http://www.riaa.com> for more information.

## 2.9 Product information on acrylic panels

---

The acrylic panels for the tanning devices are produced of acrylic developed especially for this application. The acrylics used are characterized by a particularly high UV permeability/low resistance, as well as an easy-care, hygienic surface that is gentle to the skin.

The acrylic panels are formed for the specific devices in a technically complex production process. Despite state-of-the-art production know-how, the presence of minor spots, air bubbles or streaks in the acrylic panels is unavoidable. In addition, microfine hairline cracks can occur on the bed surface during operation.

These occurrences are material-dependent and are unavoidable. Other than appearance, they have no significant effect on the use or value and can therefore not be recognized as defects.



### **CAUTION!** **Damage to the acrylic panel.**

Cosmetics or sun screen products must be removed prior to using the sunbed as they can cause damage (e.g. fine cracks on the surface) when used continuously.

---

## **2.10 Disposal**

---

### **2.10.1 Environmental regulations – disposal of lamps**

UV low-pressure lamps and UV high-pressure lamps contain fluorescent materials and other waste containing mercury.

According to the national waste disposal laws and in accordance with the municipal waste regulations, proof must be provided of the proper disposal of UV lamps.

Contact your local environmental agency for assistance with the disposal of UV lamps.

### **2.10.2 Disposal of recyclable materials**

The device has been produced of recyclable materials. When being scrapped, the device must be disposed of properly. JK Products & Services can provide you with information on the content and potential hazards of the materials used.

## **2.11 Instruction signs on the device**

---

See page 35.

## **2.12 Technical modifications**

---

The device has been constructed in accordance with current safety regulations. The illustrations and specifications on these instructions are subject to technical modifications which are required in order to improve the device.

Unauthorized modifications and changes to the device and its control unit are prohibited.

Use only OEM spare parts.

**3**

**Operation**

**3.1 Mandatory reading**

---

Always read and follow all instructions for proper usage prior to allowing anyone to use the tanning device. The operating instructions included with this device must always be followed to prevent possible injuries.

Inform users

- to use provided UV-blocking protective eyewear whenever the equipment is energized.
- to follow the exposure schedule in accordance with their skin type. Failure to do so may result in overexposure.

A tanning system is not a toy. You cannot vary the strength of the lamps in your unit.

Should you have any questions regarding the proper use of your tanning system, contact Global Service USA at:

☎ 800 445 0624

Mon - Fri. 8:00 a.m. to 7:00 p.m. (CT)

Sat. 8:00 a.m. to 3:00 p.m. (CT)



**WARNING!**

**WARNING – ULTRAVIOLET RADIATION!**  
**Danger of skin injuries and skin diseases.**

- The sunbed must never be used when a filter panel is missing or damaged, or the timer is defective!



**NOTE:**

When describing the operation, the tanning device is often shown with the canopy open. During tanning the canopy must always be closed.

Proper operation is not possible with the canopy open.

**3.2 Use the sunbed – but use it properly!**

---

A few things need to be noted to get maximum enjoyment from a sunbed. Here are some answers to some frequently asked questions.

**Make-up on the sunbed?**

Please remove make-up or don't use make-up while tanning. Clean skin absorbs UV light better.

A wide variety of ingredients are found in cosmetics. Again, whether these are emulsifiers, greases, or so-called scents – in conjunction with UV radiation, these can cause allergic reactions of the skin.

Accordingly, it is essential to remove all make-up before using the sunbed. Make-up clogs the pores in the face. The UV light from a sunbed re-opens these clogged pores so that not only does the light penetrate the skin, but also the allergenic components of the make-up.

A further negative consequence of make-up is that the appearance of the skin deteriorates irreversibly over a period of time regardless of the quality of cosmetics used. Therefore, remove all make-up before a session in the sunbed.

**Showering after leaving the sunbed?**

The browning is in the skin, not on it. Therefore you cannot wash it off. Treat your skin to a moisturizing cream after showering.

**Are medications and the sunbed compatible?**

It is known that some medications increase the skin's sensitivity to UV light. This probability is particularly high with antibiotics, sulphonamides, psychiatric drugs, tranquillizers, anti-diabetes treatments and diuretics. Sun creams which contain psorale or kumarin also increase skin sensitivity. If you are in any doubt, first ask your doctor - then you can enjoy the sun without risk of drug interactions.





**Contact lenses on the sunbed?**

The answer is: Yes! Like any other sunbed user, contact lens wearers should also wear special protective goggles which protect the eyes against UV radiation. To guarantee better protection, wearers of glasses or contact lenses should ask their optician for contact lenses with UV protection. The UV-A and UV-B filters built into some contact lenses will protect the cornea and the internal parts of the eye against almost 100% of the energy in UV radiation.

This will benefit sunbed users not only in the sunbed, but during everyday exposure to UV radiation as well. For more information, ask your optician or optometrist.

**3.3 Operation overview: SUNDASH / XXS**

**3.3.1 Functions**

Function	Button sequence	Description	Information
1. UV lamps		<b>Start/Stop</b> Switch the UV lamps on / off during tanning	
2. Time		Set tanning time	
3. Body cooling/ Facial cooling		Control cooling, Levels 1-2 Switch off cooling Switch on cooling	 The air jets for the facial cooling can be adjusted by hand.
4. Face tanner (if available)		Switch off face tanner Switch on face tanner	1 minute until maximum power.

### 3.4 Operation overview: FLAIR / PASSION / XS

#### 3.4.1 Navigation

The device is operated with the navigation ring.

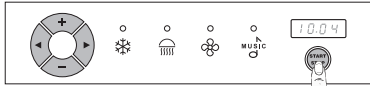

11851 / 0



Switch on UV lamps:

- Press the button once.

Switch off UV lamps/pause tanning:

- Hold the button down.

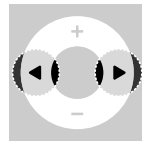

Select device function (go to pictogram)

MUSIC e.g. MUSIC



Adjust the intensity/setting of the function selected

The available functions and the navigation ring are illuminated in default mode after starting up the tanning device. After selecting a function, the respective LED and the navigation will ring flash for a few seconds. Settings may be changed during this time.

#### 3.4.2 Functions

Function	Button sequence	Description	Information
1. UV lamps		START/STOP switch the UV lamps on / off during tanning	If the UV lamps are switched off during tanning, the tanning time continues to run.
3. Music		Internal: Control volume, Levels 0-14 External: MP3 player	Only available as optional accessories for Stereo-Sound and Stereo-Sound PLUS. See page 14
4. Body cooling/ Facial cooling		Control cooling, Levels 1-5 Switch off cooling <input type="checkbox"/> OFF Switch on cooling <input type="checkbox"/> ON	 The air jets for the facial cooling can be adjusted by hand.
5. Facial tanner		Switch off facial tanner <input type="checkbox"/> OFF Switch on facial tanner <input type="checkbox"/> ON	1 minute until maximum power is reached.
6. Air conditioning system		Switch off air conditioning <input type="checkbox"/> OFF Switch on air conditioning <input type="checkbox"/> ON	

## 3.5 Start

The device is started automatically with an internal or external timer.



### NOTE:

Timer instructions see separate manual (order no. 0070923801-..)

### 3.5.1 Preparation time

Example:

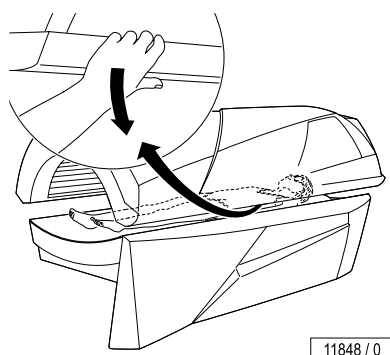

Before the UV lamps turn on, you have a few minutes to prepare yourself. During the preparation time you can switch on the UV lamps at any time by pressing the START/STOP button.

- Remove your clothes and all jewelry.
- Remove make-up and other cosmetics.
- Remove glasses. Contact lenses can be worn under the protective goggles.
- Put on the protective goggles.
- Lie down on the bed surface.
- Close the canopy.
- Press the START/STOP button.

Settings on start-up:

- UV lamps
- Facial tanner
- Cooling
- Stereo Sound System PLUS (optional)
- Air condition (optional)

### 3.5.2 Interrupt or end tanning session

The tanning session ends automatically after the preset time has run down. The internal fan continues to run for approx. three (3) minutes to sufficiently cool the device.

- To interrupt a tanning session, press button START/STOP anytime during a session.
- Press START/STOP again to restart the lamps.

### 3.6 MP3 player connection

 **WARNING!**  
**Danger of hearing damage!**

**WARNING!**

Using earphones or headphones at high volume can result in permanent hearing damage.

Improper maintenance can cause the device to be damaged or to become unusable.

- Do not set the volume too high.

Studio customers can connect their own MP3 player to the device when the "Stereo Sound System PLUS" accessory is available

- 1 Jack plug (JK Part # 4630911001-..) provided for use by the studio operator (2 x 3.5 mm stereo jack plug).
- 2 MP3 player connection: see the documentation from the manufacturer of the MP3 player.

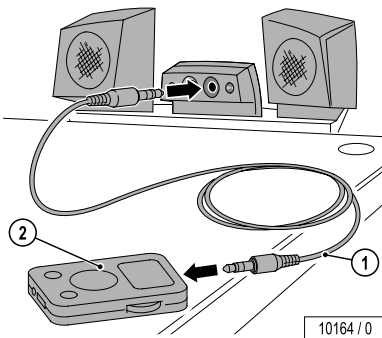

Loud music might disturb other studio users!

- Use headphones whenever necessary.

**Connect:**

- Plug the MP3 cable (stereo jack plug) into the Stereo-Sound system PLUS.
- Plug the MP3 cable into the MP3 player.
- Select the music title and start in accordance with your MP3 player's instructions.

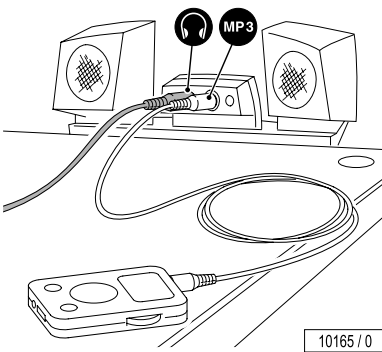

If the speakers do not play any music:

- Increase the volume on the MP3 player until the music signal is automatically switched to the Stereo-Sound system PLUS.
- Set the volume on the tanning device to the desired level.

**CAUTION!**

**The heat might damage your MP3 player.**

Do not position the unit so that it receives direct tanning radiation.

**Cable may be torn off, connectors may be damaged.**

- Do not pull on cable when unplugging MP3 player.

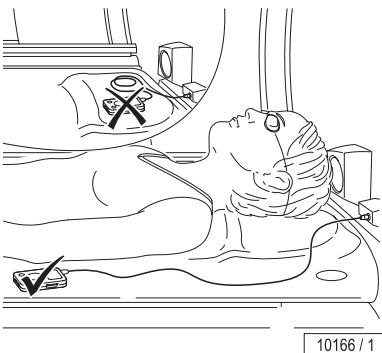

## 4 Cleaning and maintenance

### 4.1 Safety instructions for cleaning and maintenance



**DANGER!**

#### **EXTREME DANGER – HIGH VOLTAGE!**

**You can be killed or injured by an electric shock!**

During maintenance work there is a risk of touching live parts and receiving a fatal electric shock.

- Disconnect device from power supply before opening.
- Do not reach behind covers and do not open the device with the device switched on.
- Refit any safety devices (e.g. switches) after the work has been completed.

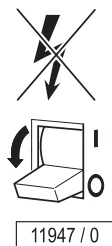

11947 / 0

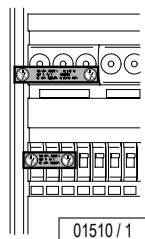

01510 / 1

If work is to be performed on the devices, they must be powered off. This means that all live lines must be switched off.

Switching off the device alone is insufficient, as certain points may remain energized. Therefore, switch off and lockout circuit breakers before performing any work

Severe accidents can occur if the device is mistakenly switched on again. Immediately after powering off, secure all switches or fuses used for power against being switched on again.

A strip of adhesive tape with the wording "DANGER do not switch ON!" may be applied over the actuation levers of circuit breakers which cannot be removed.

A prohibition sign with the text:

"Work in progress!"

"Place: ....."

"Sign may only be removed by: ....."

must always be securely mounted immediately.

#### **EXTREME DANGER!**

Prohibition signs must not be hung on or touch live parts.

It is imperative that you, the owner and/or operator, check all components for any signs of wear which may occur through normal use.

- Observe the cleaning and maintenance schedule specified in the tables in Chapter 6.1 and 6.2 (Operating Instructions Part II).

Only replace UV low-pressure lamps with the original type or compatible lamps.



Should you require any assistance or need additional information, please call Global Service USA at 800 445 0624, Monday through Friday 8:00 a.m. - 7:00 p.m. CT, Saturday 8:00 a.m. to 3:00 p.m.



**WARNING!**

**WARNING!**

**Injuries and damage due to improper maintenance!**

If the maintenance intervals for the UV lamps are exceeded or incompatible UV lamps are installed, the share of harmful UVB radiation may increase. Sunburn and other skin damage may result.

Improper maintenance can cause the device to be damaged or to become unusable.

- Always comply with the specified maintenance intervals.
  - Follow the cleaning instructions.
- 



**WARNING!**

**WARNING!**

**Danger of burns from hot lamps and device parts.**

If the tanning device was operated before being switched off and opened, lamps and housing parts may be hot.

- Before replacing lamps or other spare parts, wait until lamps and metal parts of the device have cooled down sufficiently.
- 



**WARNING!**

**WARNING!**

**Danger of pinching.**

When opening and closing the tray, panels and covers, you can pinch your fingers.

---

---

## 4.2 Malfunctions

---

The display shows error codes to make it easier to localize the cause of the problem.

- If a malfunction occurs, the error code flashes in the display.
- If several malfunctions occur, the error messages are displayed alternately.
- The fault remedy is acknowledged by holding down the **START/ STOP** button.
- If the problem cannot be remedied, inform Customer Service – see Page 2.

For further information see separate instructions “Error Codes”.

---

## 4.3 Cleaning

---



**WARNING!**

### **WARNING – RISK OF INFECTION!**

**Infections can be transferred through skin contact.**

All items/equipment components, with which the user can come into contact during tanning, must be disinfected after every tanning session:

- Acrylic
- Handles and control panel
- Protective goggles
- MP3 cable

Use only approved cleaners to disinfect the tanning system and its components.

---

### 4.3.1 Disinfection

For hygienic proper disinfection, use a specially developed disinfectant cleaner.



#### **NOTE:**

For thorough disinfection, the product must be allowed to remain in contact with the surface being disinfected for a specified amount of time. Follow the manufacturer's instructions for use.

## 4.3.2 Cleaning of surfaces

### Acrylic surfaces



#### **CAUTION!**

**Do not rub with a dry cloth – danger of scratching!**

- For hygienic proper cleaning of acrylic surfaces, use a specially developed disinfectant cleaner.

Other cleaning agents, especially concentrated disinfectants or solvents (e.g. Lysoform, ethyl alcohol or other liquids containing alcohol) must never be used for cleaning.

**Failure to observe this voids all warranty claims.**

---

### Plastic surfaces

For cleaning the painted and unpainted plastic surfaces, it is best to use warm water and a leather cloth. Never use aggressive cleaning agents containing alcohol or essential oils as they may lead to long-term damage not covered by the warranty.

During cleaning, a slight discoloration of the leather cloth by the rubber seals must be expected for production-related reasons.

#### **Prevent damage to plastic surfaces.**

- Remove rings, watches, bracelets etc. before the start of cleaning work.

## 4.3.3 Filter panels and lamps

- Low-pressure UV lamps and filter panels can be cleaned with a damp cloth and without additional cleaning agents where necessary.
- High-pressure UV lamps may be cleaned with ethyl alcohol where necessary.

---

## 4.4 Cleaning plan – see Operating Instructions Part II

---

**NOTE:**

Cleaning must be confirmed after each tanning session by pressing the START/STOP button (when the cool-down time for the main fan has finished if the parameter is enabled, function is activated).

---

## 4.5 Maintenance

---

Maintenance and care play a major role in deciding the devices performance and appearance over its useful life. Diligent compliance at the specified intervals is absolutely necessary to ensure the proper operation of your tanning system.

The current operating hours of the parts requiring maintenance can be displayed in the Presetting mode – see separate instructions “Presettings”.

Please note that the device must be inspected regularly by a JK authorized representative every 12 months (from date of commissioning) to maintain its proper condition!

### 4.5.1 Acrylic base

Over the course of time the acrylic base will become discolored as a result of usage and must be replaced on a regular basis.

The optional intermediate panel (only for devices with an air conditioning unit) works as a UV filter and must be replaced on a regular basis.

---

## 4.6 Maintenance plan – see Operating Instructions Part II

---

**CAUTION!**

Only use **OEM** spare parts of the same type! The use of other parts will limit or void your manufacturer's warranty!

Any liability is excluded in case of damage or injury proven to be the result of the use of non-genuine spare parts.

---

## 4.7 Disassembly for cleaning and maintenance work

---

Where necessary the base, the canopy panel or the front panel can be disassembled.



**DANGER!**

**EXTREME DANGER – HIGH VOLTAGE!**

**You can be killed or injured by an electric shock!**

During maintenance work there is a risk of touching live parts and receiving a fatal electric shock.

- Disconnect device from power supply before opening.
  - Do not reach behind covers and do not open the device with the device switched on.
  - Refit any safety devices (e.g. switches) after the work has been completed.
-

### 4.7.1 Removing the base

- Remove the screws and remove the washers.

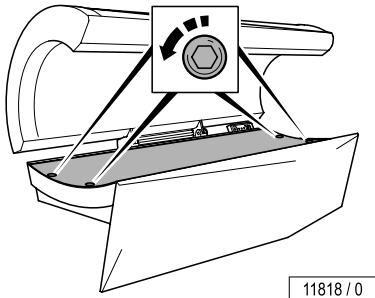

11818 / 0

- Push the base to the rear in order to lift it out of the guide.

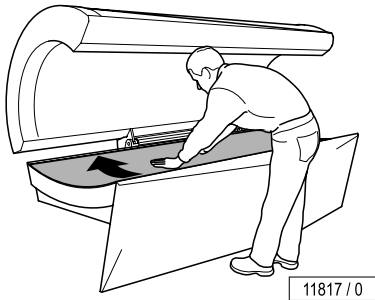

11817 / 0

- Remove the base and carefully lay it aside.

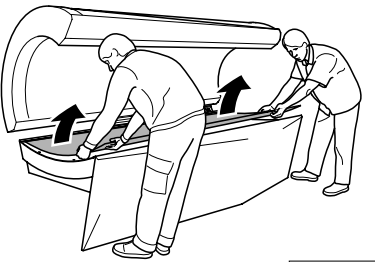

11816 / 0

The assembly is the same process in reverse order.

**When assembling the sunbed please note:**

- Carefully lay the base in the guide.

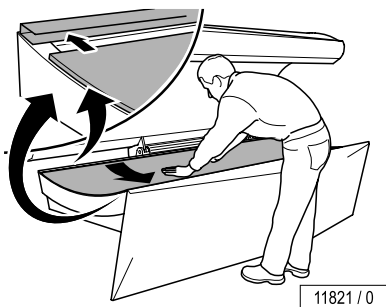

11821 / 0

## 4.7.2 Removing the canopy panel

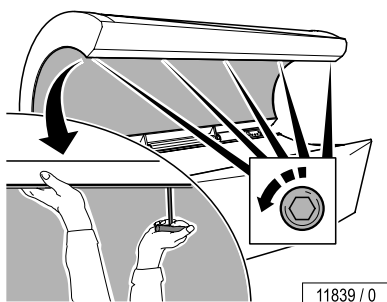

- First remove the outside screws and then remove the screws in the middle.
- Support the canopy panel with one hand so that it does not fall down.

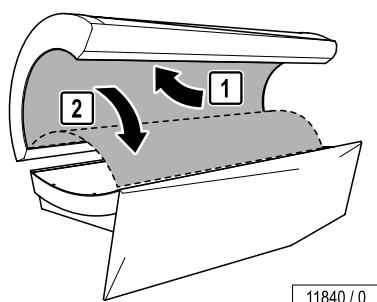

- Press lightly against the canopy panel in order to lift it out of the guide.
- Carefully lay the canopy panel aside.
- Protect the base against scratches.

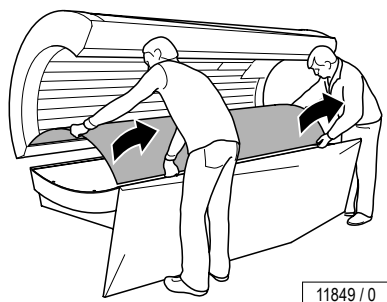

- Remove the canopy panel with the aid of a helper.

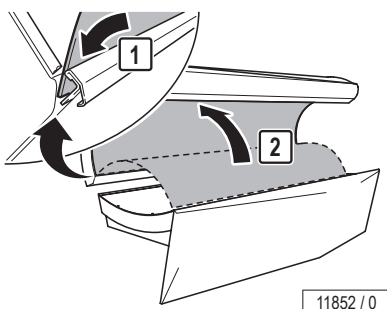

The assembly is the same process in reverse order.

### When assembling the sunbed please note:

- Carefully lay the canopy panel in the guide.

### 4.7.3 Removing the front panel

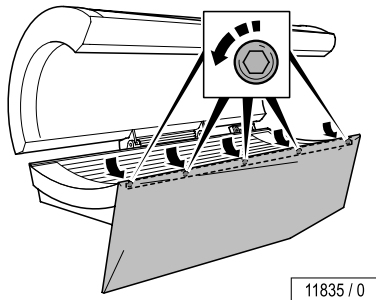

- Remove the base: see page 21.
- Remove the screws from the inside.

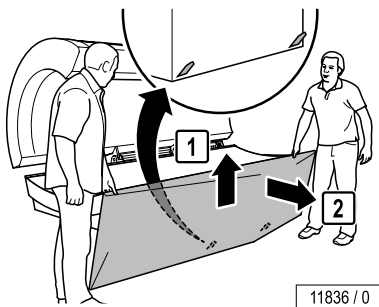

- Carefully lift the upper edge on the front panel out of clamps (pull upwards).
- Lift the front panel in order to lift it out of the two lower hooks.
- Then remove the front panel to the front and lay it aside.

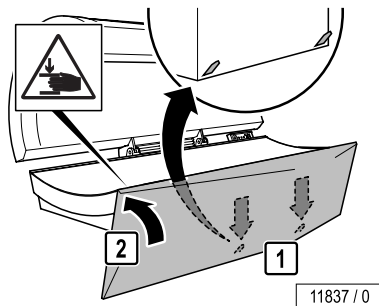

The assembly is the same process in reverse order.

#### **DANGER!**

#### **Danger of crushing fingers when inserting the front panel.**



Fingers can be jammed when pressing in the front panel.

- Do not hold fingers between the front panel and the device when pressing.



## 4.8 Instructions for changing the lamps

The UV effect of the lamps and thus the tanning effect decreases over the course of time. As such, the replacement intervals specified in the maintenance plan must be adhered to.

UV filters are utilized in order to control the UV radiation, e.g. the filter panels on the facial tanner. However, the filter effect decreases over the course of time. As such, the replacement intervals specified in the maintenance plan must be adhered to.

### 4.8.1 UV Low pressure lamps

- Replace faulty UV low-pressure lamps immediately.
  - Always replace the entire set of lamps after the specified operating time.
- Turn 90° and carefully remove from the socket.

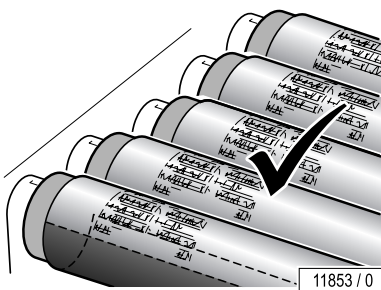
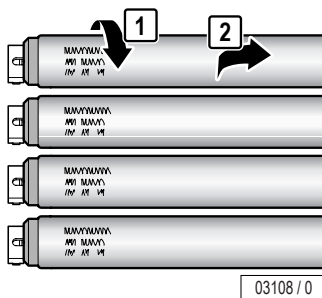

- UV low-pressure lamps possess a reflector which directs the light outwards. The lamps must be mounted in such a way that the rear side of the reflector is located on the device side.

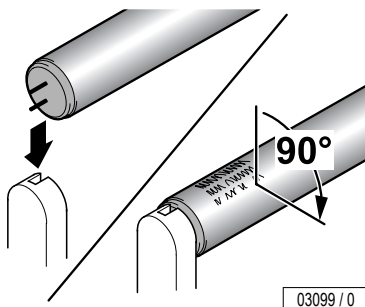

- Push the pins vertically into the socket from above.
- Turn the lamp 90°.  
The lettering must be oriented towards the outside (i.e. towards the tanning room or the user).

### 4.8.2 Starter

- Replace faulty starters immediately.

You can recognize a faulty starter by the blackened ends of the UV low-pressure lamps or when the UV low-pressure lamps can no longer be started.

Operating a UV low-pressure lamp with a faulty starter significantly shortens its service life. The UV low-pressure lamp loses power and may begin to flicker under certain circumstances.

The starters are located in either one of the two lamp sockets or are visible when the UV low-pressure lamps are removed.

- Turn 90° and carefully remove from the socket.

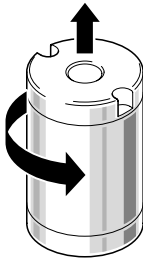

05584 / 0

### 4.8.3 High pressure lamps and filter panels

UV high-pressure lamps are used in facial tanners.

#### **DANGER!**

#### **Fire hazard due to overheated lamps!**



Non-approved high-pressure lamps can explode. Hot lamp components can set other parts on fire. People can be killed or severely injured due to smoke inhalation and fire.

- Only fit the high pressure lamps specified by the manufacturer.
- Clean the inside of the device regularly. Dust particles are flammable!

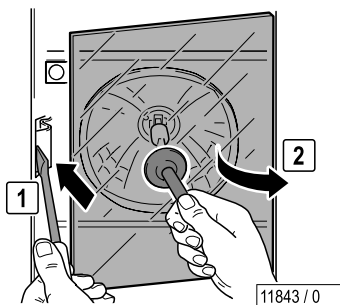

11843 / 0

- Open the clamps.
- Lift the filter panel, pull it out of the guide and remove it.

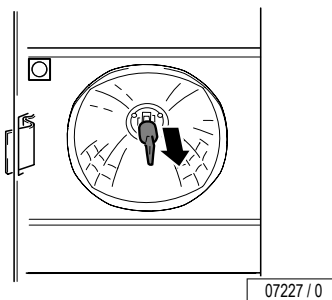

07227 / 0

- Unplug the UV lamps.
- Clean the reflector.

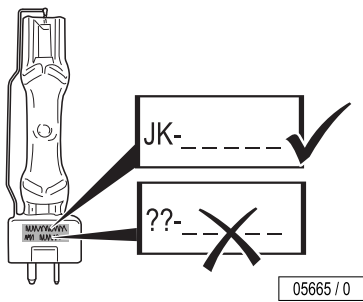

- Only utilize original UV lamps.

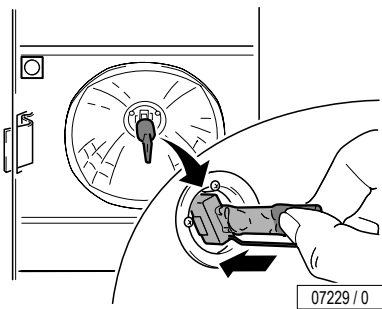

- Only touch new lamps in the handling zone.

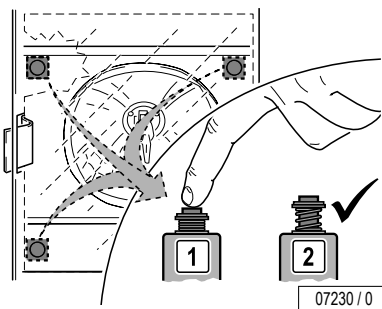

- Check the function of the safety switch.  
The safety switch is located on one of the corners of the reflector. The safety switch ensures that the device switches off in the event of a faulty filter panel.
- Press the switch.  
If the switch springs back automatically then it is functional.
- Replace the filter panel.

## 4.9 Cleaning or replacing UV lamps in the sunbed base

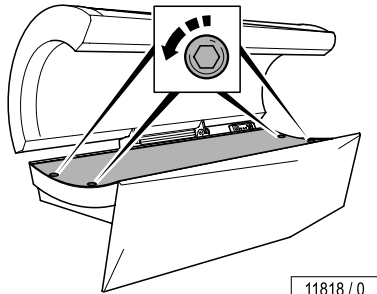

11818 / 0

- Remove the base: see page 21.

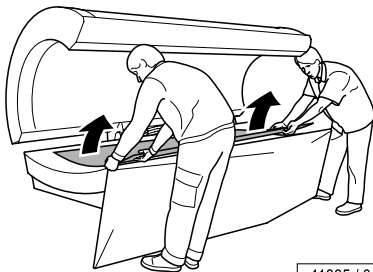

11885 / 0

- Remove the intermediate panel and carefully set aside (only for devices with an air conditioning unit).

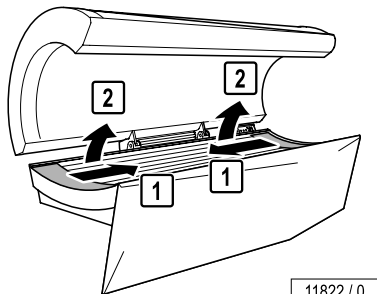

11822 / 0

- Remove the lamp coverings at the head and foot ends.  
Replacing the lamps: see page 24.  
Replacing the starter: see page 25.

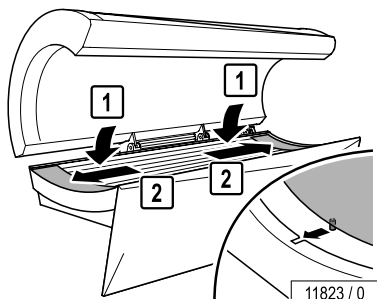

11823 / 0

The assembly is the same process in reverse order.

### When assembling the sunbed please note:

- When positioning the lamp covering push the pins into the opening.
- Carefully lay the base in the guide.

## 4.10 Cleaning or replacing UV lamps and filter panels in the canopy

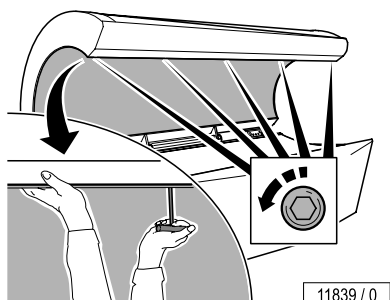

11839 / 0

- Remove the canopy panel: see page 22.

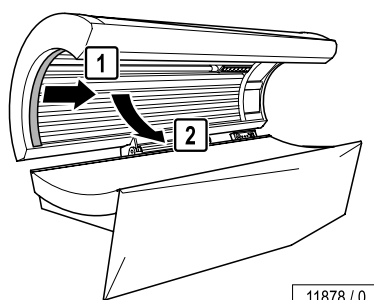

11878 / 0

- Remove the lamp cover.

Replace the lamps:

UV low pressure lamps: see page 24.

UV high-pressure lamps and filter panels: see page 25.

Replace the starter: see page 25.

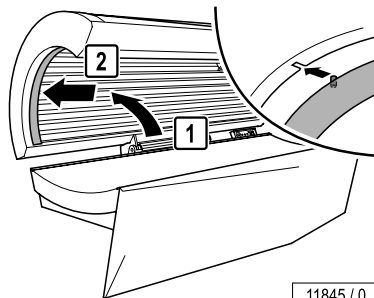

11845 / 0

The assembly is the same process in reverse order.

**When assembling the sunbed please note:**

- When positioning the lamp covering push the pins into the opening.

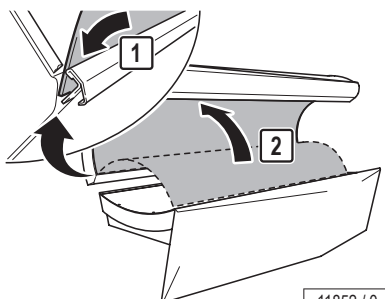

11852 / 0

- Carefully lay the canopy panel in the guide.

## 4.11 Cleaning or replacing interior lighting

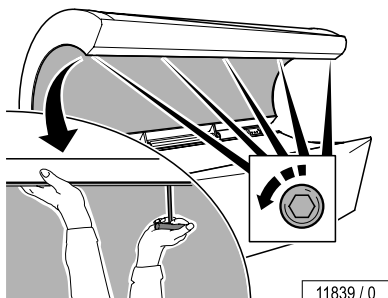

11839 / 0

- Remove the canopy panel: see page 22.

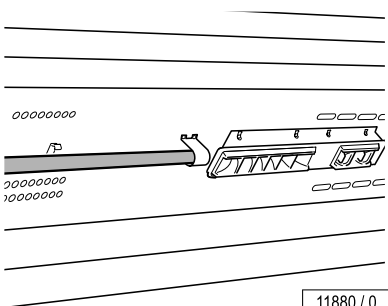

11880 / 0

Replace the lamps: see page 24.

Replace the starter: see page 25.

The assembly is the same process in reverse order.

**When assembling the sunbed please note:**

- Carefully lay the canopy panel in the guide.

## 4.12 PASSION series: Cleaning or replacing the canopy accent lighting

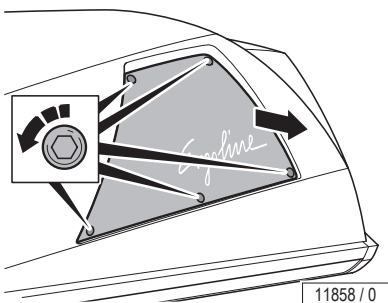

11858 / 0

- Remove the screws illustrated.

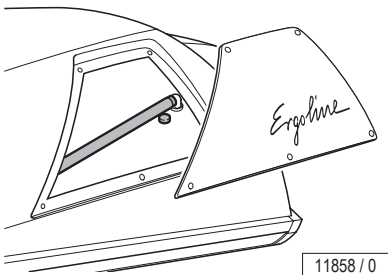

11858 / 0

Replace the lamps: see page 24.

Replace the starter: see page 25.

The assembly is the same process in reverse order.

### 4.13 Cleaning the base filter

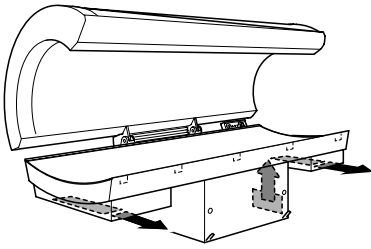

11838 / 0

- Remove the front panel: see page 23.
- Pull out the two outside filters to the front. Remove the middle filter via the top.

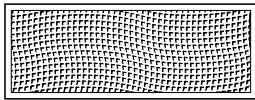

05064 / 0

- Moist or dry clean the filter.  
Dry cleaning: Vacuum cleaner (depending on the degree of soiling)  
Moist cleaning: Water and detergent, or with a dishwasher.

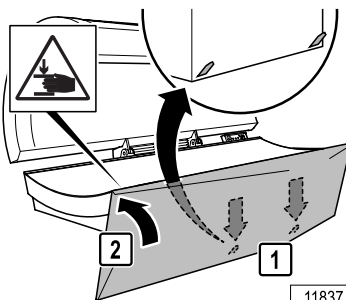

11837 / 0

- Replace the cleaned and dried filter.
- Replace the front panel.

**DANGER!**

**Danger of crushing fingers when inserting the front panel!**



Fingers can be jammed when pressing in the front panel.

- Do not hold fingers between the front panel and the device when pressing.

**WARNING!**

**Damage to the device through moisture possible.**



The cleaned filters must be dry before they are replaced.

## 5 JK-Products, Inc. – Limited Warranty

JK-Products, Inc. warrants its products to be free from defects in materials and workmanship under intended normal use as described in the unit's Operation and Instruction Manual, for a period of one (1) year from date of sale.

This Limited Warranty applies only to the original purchaser of the equipment through JK-Products, Inc. or its authorized dealer or distributor, and is not transferable.

Global Service USA obligations under this warranty are limited to repair or replacement of any defective part without charge for that part to the original purchaser, with the following exceptions:

A Fluorescent lamps are warranted against defects for a period of thirty (30) days from date of sale.

B Only parts obtained through JK-Products, Inc., its authorized dealers or distributors may be used. Transportation costs for parts shipped to the consumer and the return of defective parts to Global Service USA are not included.

C Labor will be furnished without charge for ninety (90) days from date of purchase only. All labor and related charges must be authorized by Global Service USA prior to start of repairs, and must coincide with Global Service USA established rates and time allotment policy.

D Acrylic: Refer to Manufacturer's Acrylic Warranty Policy.

It is imperative that the original customer completes and returns the enclosed warranty card within 10 days after purchase to insure valid registration and coverage for potential claims.

If the warranty card is not registered, proof of purchase from JK-Products, Inc. or its authorized dealer or distributor will be required prior to any consideration on warranty claims. This could result in service delays.

This warranty is extended to the individual or legal entity, whose name appears on the warranty registration card filed with Global Service USA, or whose name appears on the original sale document and may not be transferred to any other individual or legal entity.

This warranty does not apply to any failure of the product, or any parts of the product due to alterations, modifications, misuse, abuse, accident, improper maintenance, improper installation, acts of God or if the serial number on the product has been removed, altered or defaced. Adequate packaging must be used for returned goods to prevent freight damage.

**There are no warranties which extend beyond the description on the face hereof. There is no express or implied warranty of fitness of merchantability.**

**The remedies provided in this limited warranty are the exclusive remedies provided to the purchaser by Global Service USA and are provided in substitution of all other remedies. Consequential and incidental damages are excluded.**

No person, firm or corporation is authorized to obligate JK-Products, Inc. for any liability in connection with the sale or use of these goods.



## 5.1 Limited Acrylic Warranty

---

JK Products, Inc. warrants its acrylic sheets to be free from defects in material and workmanship, under intended normal use, for a period of one (1) year from date of sale of the tanning bed. Due to the tanning lotions, cosmetics, disinfectant and improper cleaners used on tanning surfaces that cannot be controlled by JK Products, Inc., after the first thirty (30) days of warranty period acrylic will be subject to a prorated cost to the consumer.

JK Products, Inc. obligations do not include transportation charges on replacement acrylic.

JK Products, Inc. assumes no liability for the cost of removing defective sheets or installing replacement sheets, or for damage to persons or property.

To make a claim, contact an authorized dealer or distributor of JK-Products, Inc. or Global Service USA with the model number, the serial number, and the date of purchase of the bed in which the acrylic will be used.

**There are no warranties which extend beyond the description on the face hereof. There is no express or implied warranty of fitness or merchantability.**

**The remedies provided in this limited warranty are the exclusive remedies provided to the purchaser by Global Service USA and are provided in substitution of all other remedies. Consequential and incidental damages are excluded.**

### **Global Service USA**

A Div of JK Products & Services, Inc.  
#1 Walter Kratz Drive  
Jonesboro, AR 72401

☎ 800-445-0624

☎ 870-935-9046

e-mail: [support@jkamerica.com](mailto:support@jkamerica.com)

<http://support.jkamerica.com>

## 5.2 Warranty Claims

---

### 5.2.1 Policy & Procedures

#### 1. When to file a Warranty Claim:

In the event that your tanning system is not functioning properly under intended normal use as described in the unit's Operation and Instruction Manual, you may then have established cause to file a Warranty Claim.



#### **NOTE:**

Both the tanning system and legal registered owner must meet the criteria established under JK Products, Inc. Limited Warranty as described in this manual before any Warranty Claim will be considered.

#### 2. Where to call to place a Warranty Claim:

JK-Products, Inc. is supported nationwide by an extensive dealer/distributor network through whom the majority of our units are sold. These dealers/distributors are required by contract to stock sufficient parts to meet the various warranty and nonwarranty needs of their customers.

Therefore, in order for you to properly file a Warranty Claim, you must locate the name and phone number of the dealer/distributor through whom you purchased your unit. Normally this information can be easily located either on your paid invoice or other proof of purchase documentation that you received when taking delivery of the unit.

Next, notify the dealer/distributor of the serial number, model number and date unit was purchased. This will initiate the Warranty Claim process.

Upon determination of the problem, your dealer/distributor can then supply you with the part(s) and proper instructions to return your unit to working order.

Each dealer/distributor has their own internal procedure for handling Warranty Claims and credits.



**NOTE:**

JK-Products, Inc., the manufacturer, does not involve itself in the direct handling of a Warranty Claim except where mitigating circumstances apply and where required by law.



**NOTE:**

If part returned to Global Service USA proves to be operational and not defective, or if product code numbers on part do not correspond with individual unit date on file with Global Service USA, then a 30% restocking fee will be charged in addition to the retail purchase price of part.

Acknowledgment of the Agreement is not required for acceptance of the foregoing stipulations.

### **5.2.2 Labor Warranty Claim/Credit Procedures**

Global Service USA furnishes labor without charge for a period of 90 days from date of purchase. All labor and related charges must be authorized by Global Service USA prior to start or repairs, and must coincide with Global Service USA established rates and time allotment policy.

Please contact our Service Department for authorization and billing procedures.

## **5.3 Limited Lifetime Warranty**

Global Service USA warrants specific individual components of the tanning system against defects in materials and workmanship for the life of the product. Coverage is limited to units purchased after November 1, 1994.

This warranty is restricted by the following components only:

- Steel Back Panels
- Structural Steel Frame Components
- Exterior Steel Body.



**NOTE:**

Components are warranted on an individual basis and not as they may effect the complete product.

Warranty coverage does not include cosmetic abnormalities such as scratches, nicks, dents, rust, oxidation of paint or other cosmetic changes that do not interfere with the designed function of the unit.

This warranty does not include failure of the product due to alteration, modifications, misuse, abuse, improper maintenance, improper installation or repair.

This warranty is not transferable and is only applicable to the original purchaser named on a completed and registered warranty record at JK-Products, Inc. headquarters.

JK Products, Inc. obligations do not include transportation charged on the shipping of new components to the customer or on the return of defective components of the manufacturer. All freight charges must be paid by the customer.

There are no warranties which extend beyond the description on the face hereof. There is no express or implied warranty of fitness or merchantability.

The remedies provided in this limited warranty are the exclusive remedies provided to the purchaser by Global Service USA and are provided in substitution of all other remedies. Consequential and incidental damages are excluded.



**NOTE:**

Any misuse, abuse, modification, alteration, improper maintenance, improper installation, etc. of this product or its intended use will subject said party to direct responsibility and liabilities for any and all consequences resulting from such action. Furthermore, such actions will void all warranties and may relieve Global Service USA of any liabilities relating to said product.

**SUN DASH** PERFORMANCE TANNING *Soltron Ergoline*

**WARRANTY**  
Please complete, validate and return to the manufacturer by the date of purchase.

Name of Purchaser \_\_\_\_\_  
Street Address \_\_\_\_\_  
City \_\_\_\_\_  
( ) \_\_\_\_\_  
Phone Number \_\_\_\_\_  
Company name \_\_\_\_\_  
Name of Business \_\_\_\_\_  
E-mail \_\_\_\_\_

**BUSINESS REPLY MAIL**  
FIRST-CLASS MAIL PERMIT NO 295 JONESBORO AR

POSTAGE WILL BE PAID BY THE ADDRESSEE

**JK PRODUCTS & SERVICES, INC.**  
#1 WALTER KRATZ DRIVE  
JONESBORO, AR 72401

**SUN DASH** PERFORMANCE TANNING *Soltron Ergoline*

12137 / 0

## 6 Appendix

### 6.1 Signs and stickers on the device

Signs which warn of danger areas are attached to the device. The signs shown below are examples. Ensure that the instruction signs are always clearly recognizable and easily legible. Example: PASSION 40/3

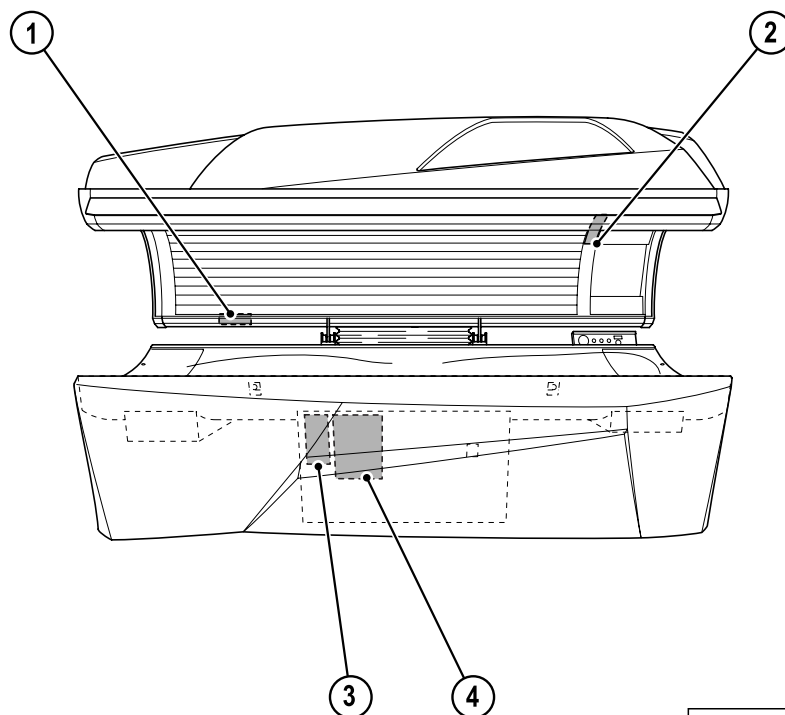

12077 / 0

#### 1 Nameplate

JK Products and Services, Inc. #1 Walter Kratz Dr. Jonesboro, AR 72401 1-800-SUNDASH		MODEL NO.
	ETL LISTED US PORTABLE SUN/HEAT LAMPS	SERIAL NO.
	INTERTEK TESTING SERVICES NA INC. CORTLAND, NEW YORK, 13045	
DATE MANUFACTURED	A/C VOLTS	A/C LAMPS
	0 0	
THIS PRODUCT IS IN CONFORMITY WITH PERFORMANCE STANDARDS FOR SUNLAMP PRODUCTS UNDER 21 CFR PART 1040:		
<b>CAUTION</b> READ OWNERS MANUAL BEFORE INSTALLING. FOLLOW ALL MANUFACTURER INSTRUCTIONS COMPLETELY AND CAREFULLY. OBSERVE AND FOLLOW ALL CAUTION WARNINGS. INSTALLATION SHOULD ONLY BE COMPLETED BY A QUALIFIED ELECTRICIAN.		

12075 / 0

The nameplate contains important information for identifying the device (e.g. the serial number = Serial-No.).

## 2 Warning sticker

**WARNING-ULTRA VIOLET RADIATION - FOLLOW INSTRUCTIONS - FAILURE TO USE PROTECTIVE EYEWEAR MAY RESULT IN SEVERE BURNS OR OTHER EYE INJURY -IF DISCOMFORT DEVELOPS, DISCONTINUE USE AND CONSULTA PHYSICIAN.**

- (I) As with natural sunlight, overexposure can cause eye injury and sunburn;
- (II) Repeated exposure may cause premature aging of the skin and skin cancer;
- (III) Medications or cosmetics applied to the skin, may increase sensitivity to ultraviolet light;
- (IV) A person who does not tan in the sun most likely will not tan from the use of this device;
- (V) A person having a history of skin problems should consult a physician before use;
- (VI) Overexposure should be avoided; and
- (VII) Children, the elderly, or fair skinned people who always burn easily and either never tan or tan minimally should not use this equipment.
- (VIII) The appliance is not allowed to be used by more than one person at the same time.

**ATTENTION - RAYONNEMENTS ULTRAVIOLETS - VEUILLEZ SUIVRE LES INSTRUCTIONS SUIVANTES - SANS DISPOSITIF DE PROTECTION DES YEUX, CE PRODUIT PEUT CAUSER DES BRULURES OU LESIONS OCULAIRES GRAVES - EN CAS DE PROBLEME ARRETER L'UTILISATION ET CONSULTER UN MEDECIN.**

- (I) Comme avec les rayons solaires naturels, une exposition trop longue peut causer coup de soleil ou brûlure;
- (II) Une exposition répétée peut causer un vieillissement prématuré de la peau ou un cancer de la peau;
- (III) L'utilisation de certains médicaments ou produits appliqués sur la peau peut accroître la sensibilité aux ultra-violet;
- (IV) Les personnes ne bronçant pas au soleil ne feront probablement pas sur cet appareil;
- (V) Toute personne ayant des problèmes de peau doit consulter un médecin avant toute utilisation;
- (VI) Eviter toute surexposition;
- (VII) Il est conseillé aux enfants, aux personnes âgées ou aux personnes à peau claire ne bronçant pas ou étant très sensibles au soleil de ne pas utiliser cet appareil;
- (VIII) L'appareil ne doit être utilisé que par une seule personne à la fois.



801140-01-

12076 / 0

## 3 USA mains connection sticker (1504659-..)

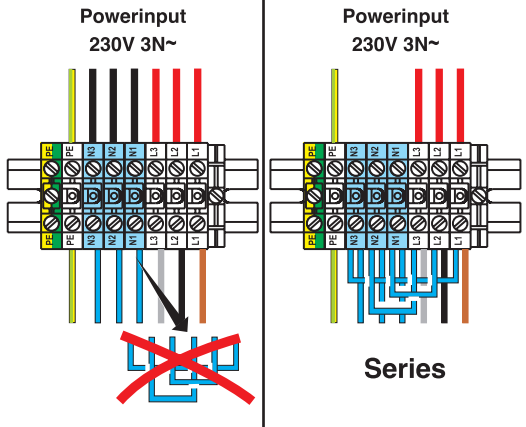

**Powerinput 230V 3N~**

**Powerinput 230V 3N~**

**Series**

**1504660-00-**



**⚠ DANGER**

**HAZARDOUS VOLTAGE.**  
Contact will cause electric shock!  
Disconnect and lock out power before servicing.

**⚠ DANGER**

**TENSION DANGEREUSE.**  
Tout contact entrainera une décharge électrique! Débrancher et sécuriser l'alimentation électrique avant de procéder à l'entretien.

**⚠ PELIGRO**

**VOLTAJE PELIGROSO.**  
¡El contacto producirá una descarga eléctrica! Desconectar y bloquear la corriente antes de trabajar.

11995 / 0

The sticker is visible when the front panel is removed and the control unit cover opened.

## 4 USA power supply units sticker

The sticker is visible when the front panel is removed and the control unit cover opened.

## 7 Index

### A

Accent lighting.....	29
Acrylic base (product information).....	19
Acrylic glass, care).....	18
Air supply planning.....	7

### B

Base removing.....	21
--------------------	----

### C

Canopy panel removing.....	22
Cleaning.....	15-18
Lamps, filter panels.....	18
Cleaning plan.....	19
Contact lenses.....	11
Copyright (Audio/MP3).....	8

### D

Definitions.....	5
Disinfection.....	17
Disposal.....	9

### E

Error codes.....	17
Export.....	8

### F

Facial tanner	
Cleaning/replacement.....	28
Filter	
Cleaning.....	30
Filter panels.....	25
Cleaning/replacement.....	28
Front panel removing.....	23
Functions.....	11, 12

### G

Glasses.....	10
Guidelines.....	7

**H**

High pressure lamps, fire hazard! ..... 25

**I**

Installation location..... 7  
Instruction signs ..... 9  
Intended use ..... 6  
Interior lighting, replacing ..... 29

**L**

Limited acrylic warranty..... 32  
Limited lifetime warranty..... 33  
Limited warranty..... 31  
Limits of installation location..... 8  
Low-pressure lamps replacing ..... 24

**M**

Maintenance..... 15, 19  
Make-up ..... 10  
Malfunctions ..... 17  
MP3 music ..... 8  
MP3 player connection..... 14

**N**

Nameplate ..... 35  
Navigation ring ..... 12

**O**

Operating panel..... 12  
Operation overview ..... 12

**P**

Plastic surfaces (Care)..... 18  
Powerinput ..... 36  
Acrylic information ..... 8

**R**

Recycling..... 9

**S**

Safety instructions, maintenance ..... 15  
Settings on start-up ..... 13  
Signs and stickers ..... 35  
Staff training ..... 7  
Start of tanning ..... 13  
Starter replacing..... 25  
Studio operator, information ..... 6

**T**

Technical modifications .....	9
Technical service .....	2

**U**

UV lamps in the sunbed base, replacing .....	27
--	----

**V**

Ventilation .....	7
-------------------	---

**W**

Warning sticker .....	36
Warranty .....	31
Warranty claims .....	32





# JK GLOBAL SERVICE

*Ergoline*

SUNANGEL

*soltron*

SUN DASH

**JK Global Service**  
**A Div of JK Products & Services, Inc.**

#1 Walter Kratz Drive  
Jonesboro, AR 72401  
USA

Phone: 800-445-0624

Fax: 870-935-9046

e-mail: [support@jkamerica.com](mailto:support@jkamerica.com)

<http://support.jkamerica.com>

1006322